

SMD contact pads are used exclusively on the printed circuit board (PCB) and, due to their electrical and physical properties, they are an excellent alternative for grounding of PCBs.

SMD contact pads, type S, have a conductive silicone core which is covered with a conductive silicone paste. On the bottom, they consist of a solderable tin plated copper foil.

The parts are delivered in tape & reel packaging as standard.

- High adhesion after SMT procedure
- High temperature resistance
- Excellent spring properties
- Excellent grounding characteristics
- High abrasion resistance
- Plane-parallel compression at all heights

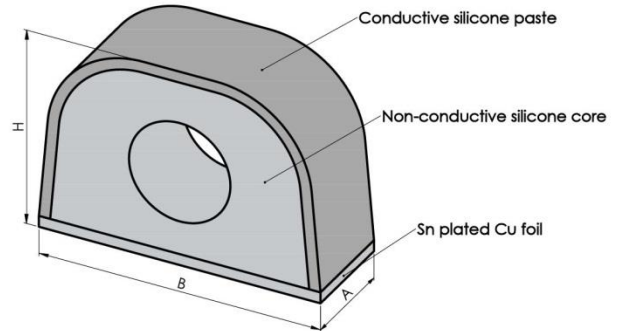

RoHS



REACH



PRODUCT SPECIFICATIONS

PROPERTY	VALUE / TOLERANCE	TEST METHOD
Basic material	Silicone rubber	-
Colour	Beige	Visual
Width (W), height (H), length (L)	See table	Digital caliper
Heat resistance	400 °C	Internal test method
Service temperature	-40 to +150 °C	Internal test method
Total mass loss (TML)	0,2% @ 280°C 1,6% @ 400°C	DIN EN ISO/IEC 17025
Electric resistance:		
• Origin	Max. 0,9Ω	HIOKI 3540 mΩ HITESTER
• Thermohygrostat	Max. 0,9Ω	
• Brine atomizing	Max. 0,9Ω	
• Thermal shock	Max. 0,9Ω	
Adhesion strength	Min. 19,6 N	UTM
Compression-deflection rate (%)	Min. 95 %	20% compression, 85°C/85%RH, 200Hr
Hardness	65 ±8 Shore A	KS M 6519
Flammability	UL94-V1 equivalence	UL94
Storage temperature	20 °C	-
Storage humidity	App. 50% rH; non-condensing	-
Shelf life	1 year	-
Guarantee	6 months	-

BUILDING AN ITEM NUMBER

SMG-S-WxHxL-SN

SMD Contact Pad	
Type S	
xxx	Width (mm)
xxx	Height (mm)
xxx	Length (mm)
Tin plated	

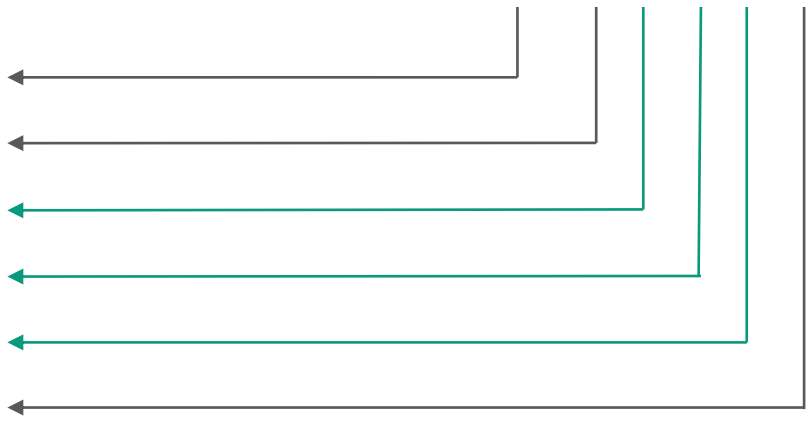

Standard options

EXAMPLE

SMG-S-2,0x1,1x1,0-SN
 SMD contact pad; type S; size: 2,0x1,1x1,0 mm; tin plated

RECOMMENDED REFLOW SOLDERING CONDITION

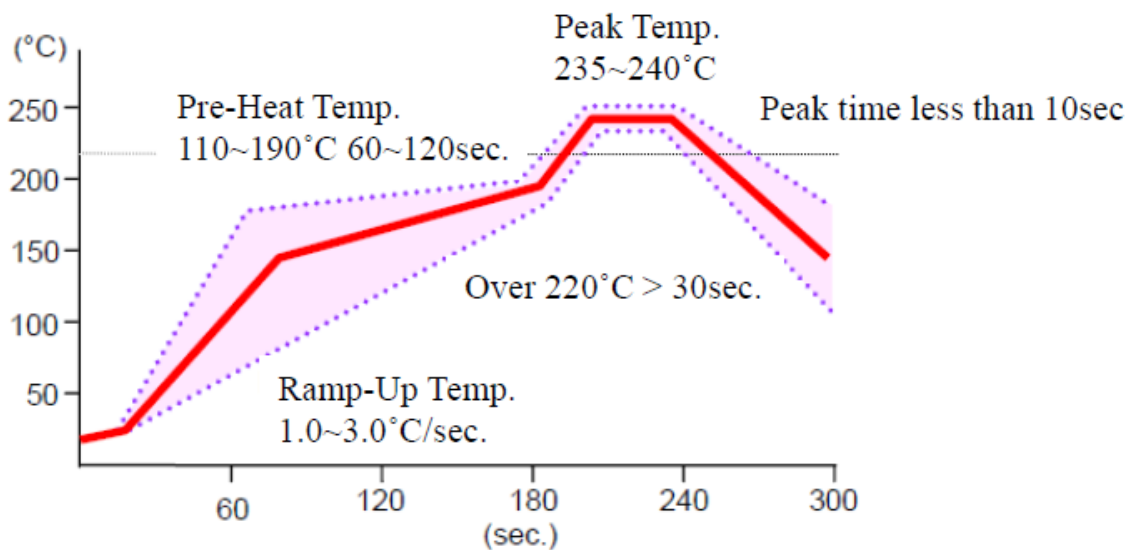

RECOMMENDED SOLDER PAD DIMENSIONS (mm)

ONE PATTERN	APPLIED RANGE	SOLDER PAD SIZE α
Width	$\leq 5,0$	+ 0,3
	$> 5,0$	+ 0,5
Length	$\leq 5,0$	+ 0,3
	$> 5,0$	+ 0,5
Metal mask thickness	0,12	

SOLDER LAND ONE PATTERN (coating & press type)

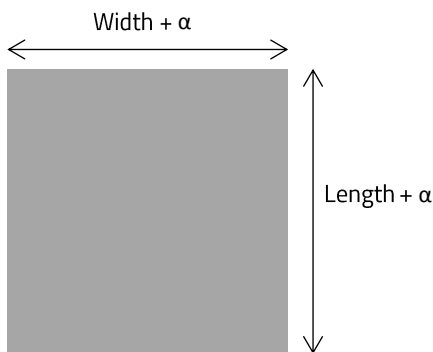

AVAILABLE STANDARD SIZES (mm)

ITEM NUMBER	WIDTH	HEIGHT	LENGTH	QUANTITY / REEL
SMG-S-2,0x0,8x1,0-SN	2,0	0,8	1,0	10.000
SMG-S-2,0x1,1x1,0-SN	2,0	1,1	1,0	10.000
SMG-S-2,0x1,4x1,0-SN	2,0	1,4	1,0	10.000
SMG-S-2,0x1,6x1,5-SN	2,0	1,6	1,5	8.000
SMG-S-2,0x1,8x1,5-SN	2,0	1,8	1,5	6.000
SMG-S-2,0x2,0x1,5-SN	2,0	2,0	1,5	6.000
SMG-S-2,0x2,5x1,8-SN	2,0	2,5	1,8	6.000